

# Operations Manual

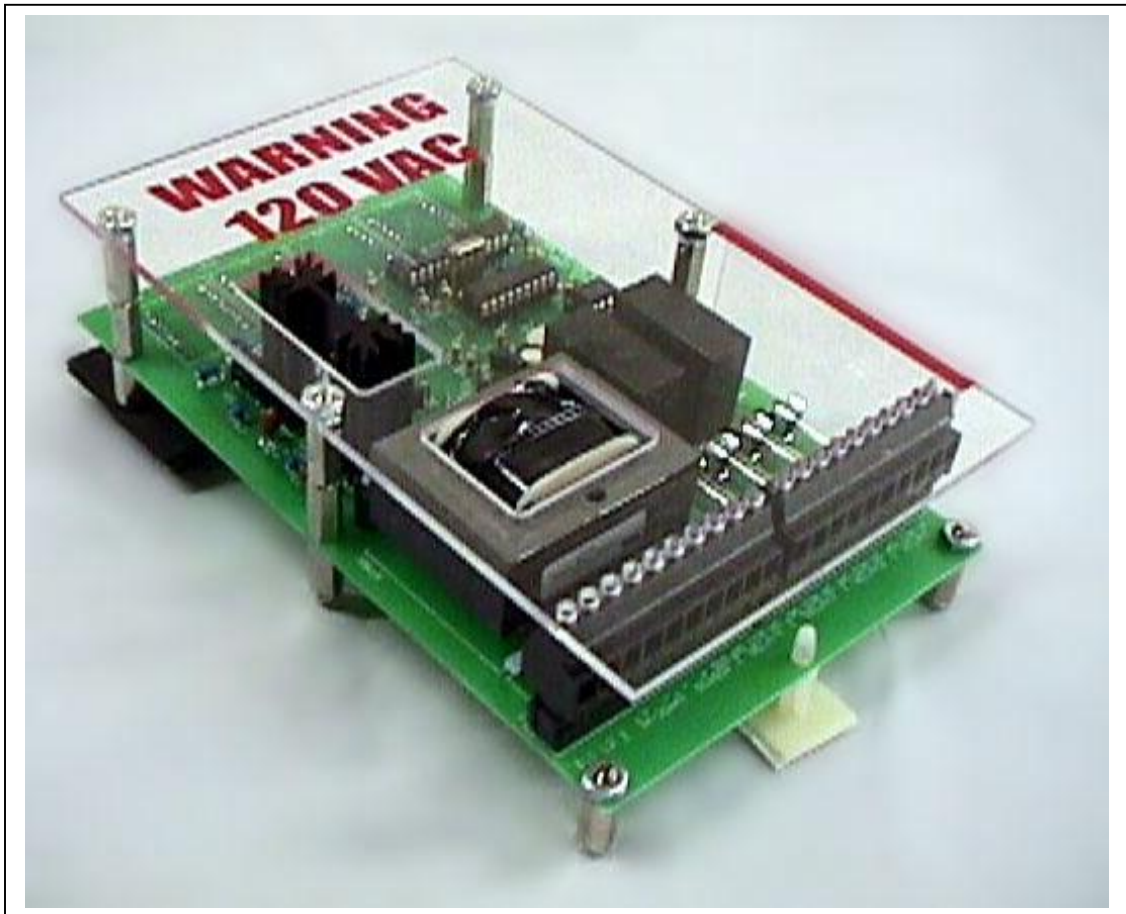

**Phares Tachometer  
Model PE-4  
120VAC**

**Operations Manual**  
Model PE4 – Open Panel Mountable Tachometer, 120VAC

**Description**

The PE-4 Tachometer is a microprocessor based, panel mount device which detects pulses (12 VDC sinking), performs calculations based on the pulses and provides an LED readout in Revolutions Per Minute (RPM), Feet Per Hour (FPH), etc. Four SPDT dry relay contact outputs and one 4-20mA scaled output are factory programmed to customer specifications.

Pulses can be provided by any sensor or encoder which meets the input specifications.

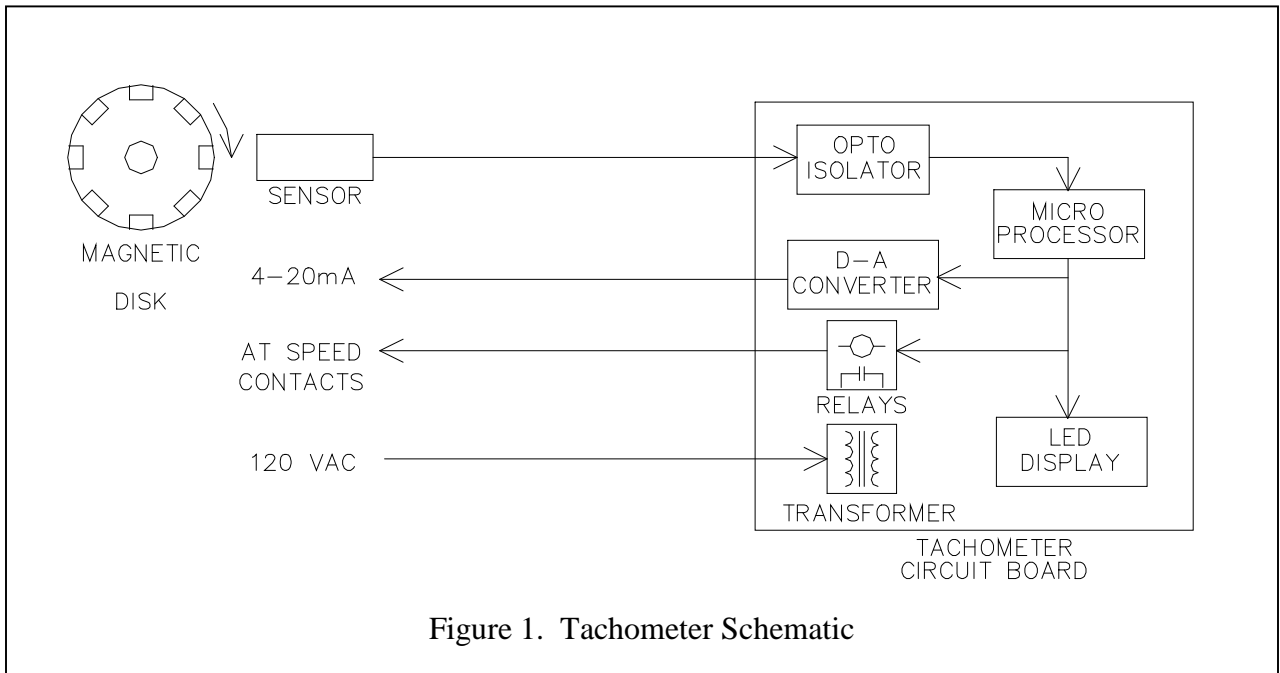

# Operations Manual

## Model PE4 – Open Panel Mountable Tachometer, 120VAC

### Wiring

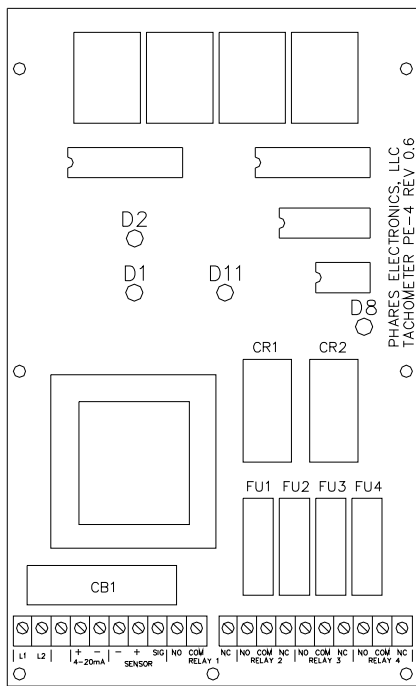

Figure 2. Tachometer Circuit Board

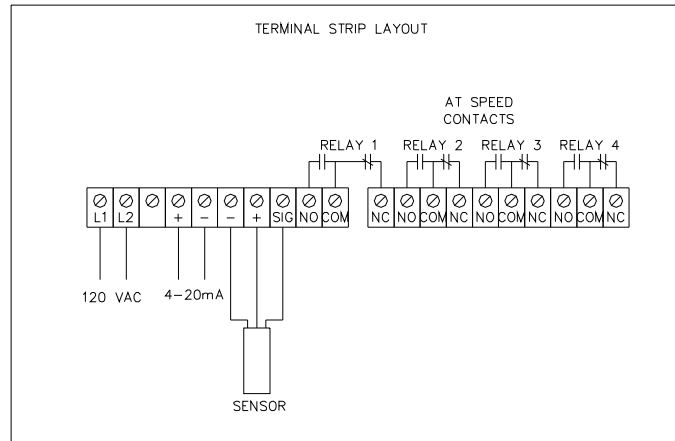

Figure 3. Terminal Strip Layout

### Troubleshooting

If the tachometer is not working properly, check the diagnostic LEDs (D1, D2, D8, D11) on the back of the unit. Then follow the troubleshooting procedures.

**1. Check Power** – There is a 5 and 12 Volt DC voltage regulator on the circuit board. Each voltage regulator drives an indicating LED to verify correct voltage. The 12VDC LED (D1) and the 5VDC (D2) should be on bright (See Figure 2. for approximate location on the board). If not, perform the following:

- A. Verify that the wiring is correct. Turn off power to the unit. Remove the sensor wires from the terminal strip and restart the unit. If the power levels return to normal, there is a problem with the sensor wiring. Check Sensor Step 2.
- B. If the problem remains, reattach the sensor wires and repeat the same test for the 4-20mA wiring, if used. If the power levels return to normal, there is a problem with the device associated with the wiring. Check the device.
- C. If the problem persists, contact the factory.

## Operations Manual

Model PE4 – Open Panel Mountable Tachometer, 120VAC

### Troubleshooting (continued)

**2. Check Sensor** – Slowly rotate the shaft. The sensor LED D8 should illuminate as the signal is received. If not, check the following:

- A. Check Power as described in Step 1.
- B. Verify sensor is 12VDC and produces a sinking output.
- C. Verify the Sensor wiring. If using Phares Electronics sensor see Table 1.
- D. Verify the gap between the Sensor and the Target. If using Phares Electronics and Disk, the gap should be 1/8 to 1/4 inch.
- E. Verify Sensor field wiring for continuity. If the field wiring is good, replace the Sensor.
- F. If Sensor LED D8 illuminates bright regardless of the motion, make sure the sensor is positioned properly to change state as the shaft rotates. If correctly positioned, the sensor +VDC and –VDC wires are reversed on the terminal strip. Correct the wiring.
- G. If the problem persists contact the factory.

Table 1. Phares Electronics Sensor Wiring

Wire Color	Function
Black	+VDC
Red	-VDC
White	Signal

Table 2. Banner® World Beam® QS18 Sensor Wiring

Wire Color	Function
White	Signal
Brown	+VDC
Blue	-VDC

**3. Check Relay** - The Relay energizes when the rotational speed exceeds a preset minimum. If the shaft is turning above the preset speed, and the Relay is not energized (indicating underspeed), perform the following tests:

- A. With the shaft above minimum speed, check the status of the Relay LED (D11).  
If the LED is on, the circuit board is functioning properly. If the LED is not on, check Power and Sensor as described in Steps 1 & 2.
- B. If the Relay LED (D11) is on, but the Relay itself is not on, there may be a faulty Relay.
- C. If the problem persists, contact the factory.

**Operations Manual**  
Model PE4 – Open Panel Mountable Tachometer, 120VAC

**Specifications**

Speed Measurement

Pulses per Revolution	Maximum Speed (RPM)	Display
8	100	0-100.0
1	4000	0-4000

Display:

Seven Segment LED, 4 Digit, with decimal point.

LED Height: 0.75"

Color: Red

Dimensions:

H x W x D

7" x 4.25" x 1.75"

Analog Output:

4-20mA, Proportional to speed.

Signal Input:

Voltage: 12VDC, Sinking

Current: < 8mA

Relay:

Contacts: Quantity of 4, NO, NC (Form C)

Contact Rating: 3A @125 VAC

Power Requirements:

Input Power: 120VAC, 60 Hz

Current : <1.0 A

Fusing:

1.0 A Circuit Breaker

**WARNING:**

The PE4 Tachometer is not rated NEMA, UL, or otherwise. It is not intended for safety critical applications.

**Operations Manual**  
Model PE4 – Open Panel Mountable Tachometer, 120VAC

**Contact Information**

Web Site: [www.PharesElectronics.com](http://www.PharesElectronics.com)

Telephone: (813) 262-0680

Mailing Address: Phares Electronics, LLC  
P.O. Box 6813  
Brandon, FL 33508  
USA

Last revised June 20, 2007

© 2007 Phares Electronics, LLC